

My CABLE TESTER 24-24

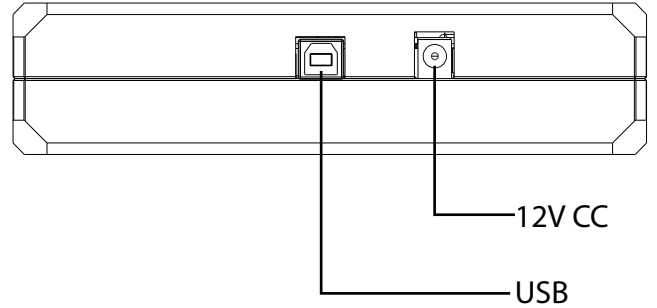

PORT A

PORT B

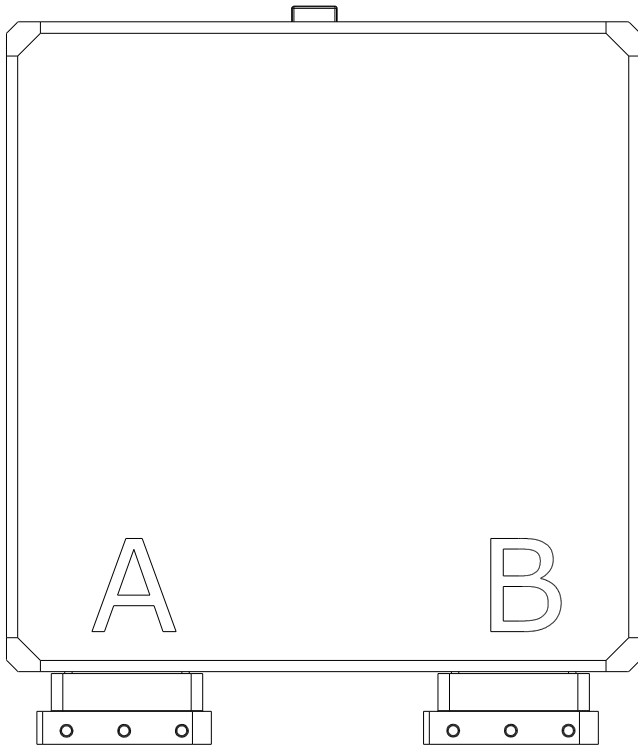
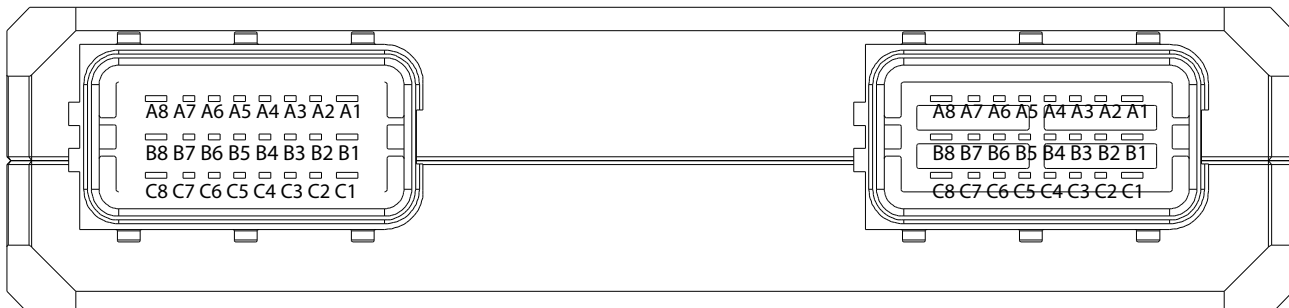

1. WIRINGS

Connect the CABLE TESTER to the PC using the supplied USB cable.
Connect the supplied 12V power supply to the 12V DC socket on the back of the CABLE TESTER.

2. WINDOWS SETTING

Press the Windows START key and type DEVICE MANAGER

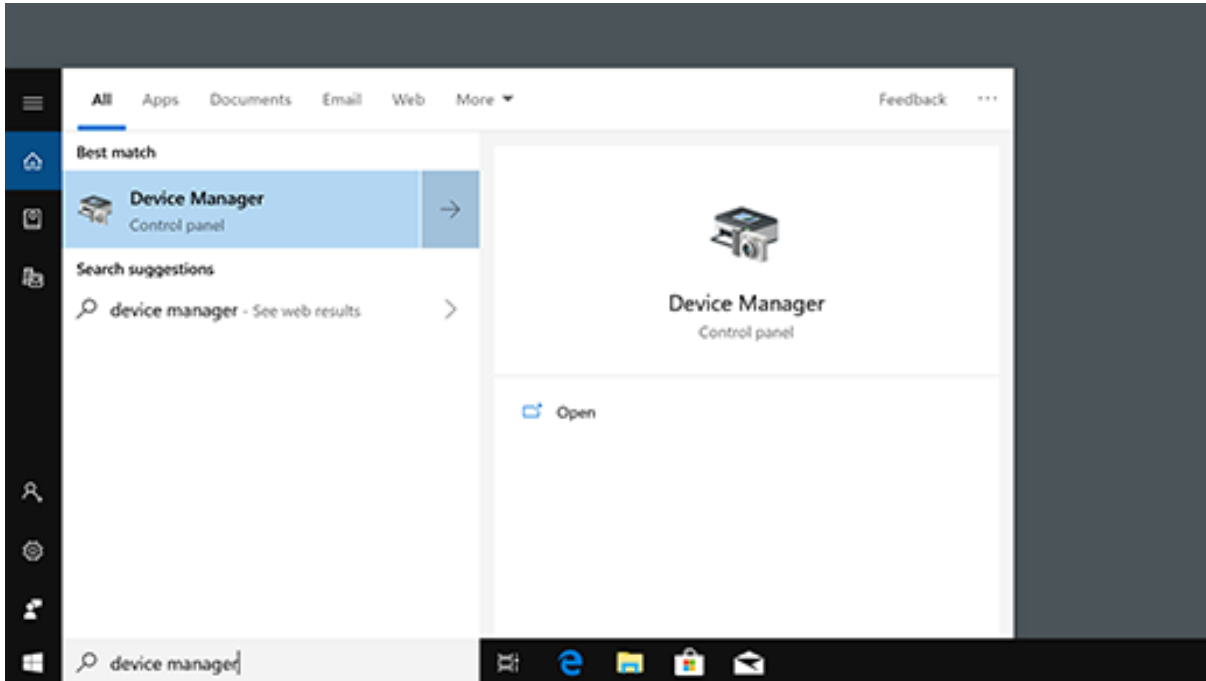

Open the CONTROL PANEL, open HARDWARE AND SOUNDS, open PORTS (COM and LPT) and look for the port number that has been assigned to the Arduino MEGA 2560 peripheral. In this case COM2.

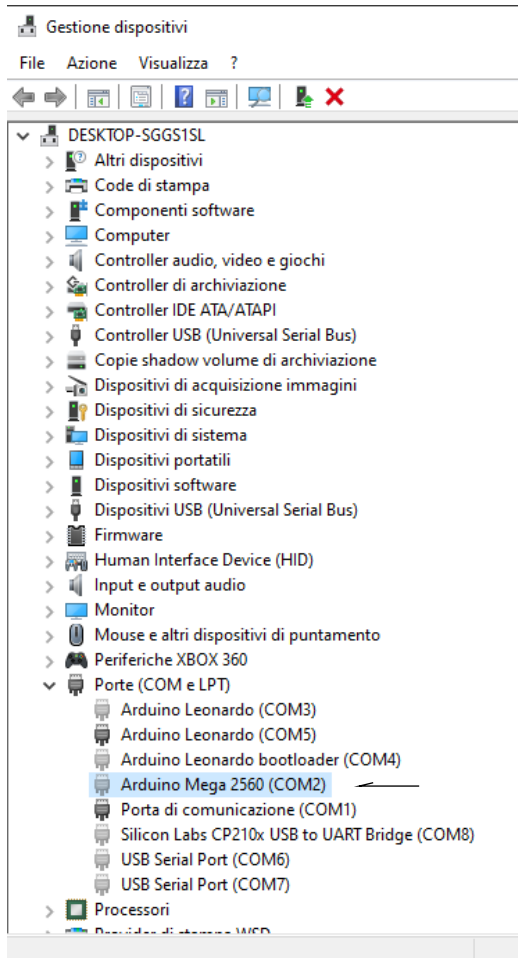

3. INTERFACE

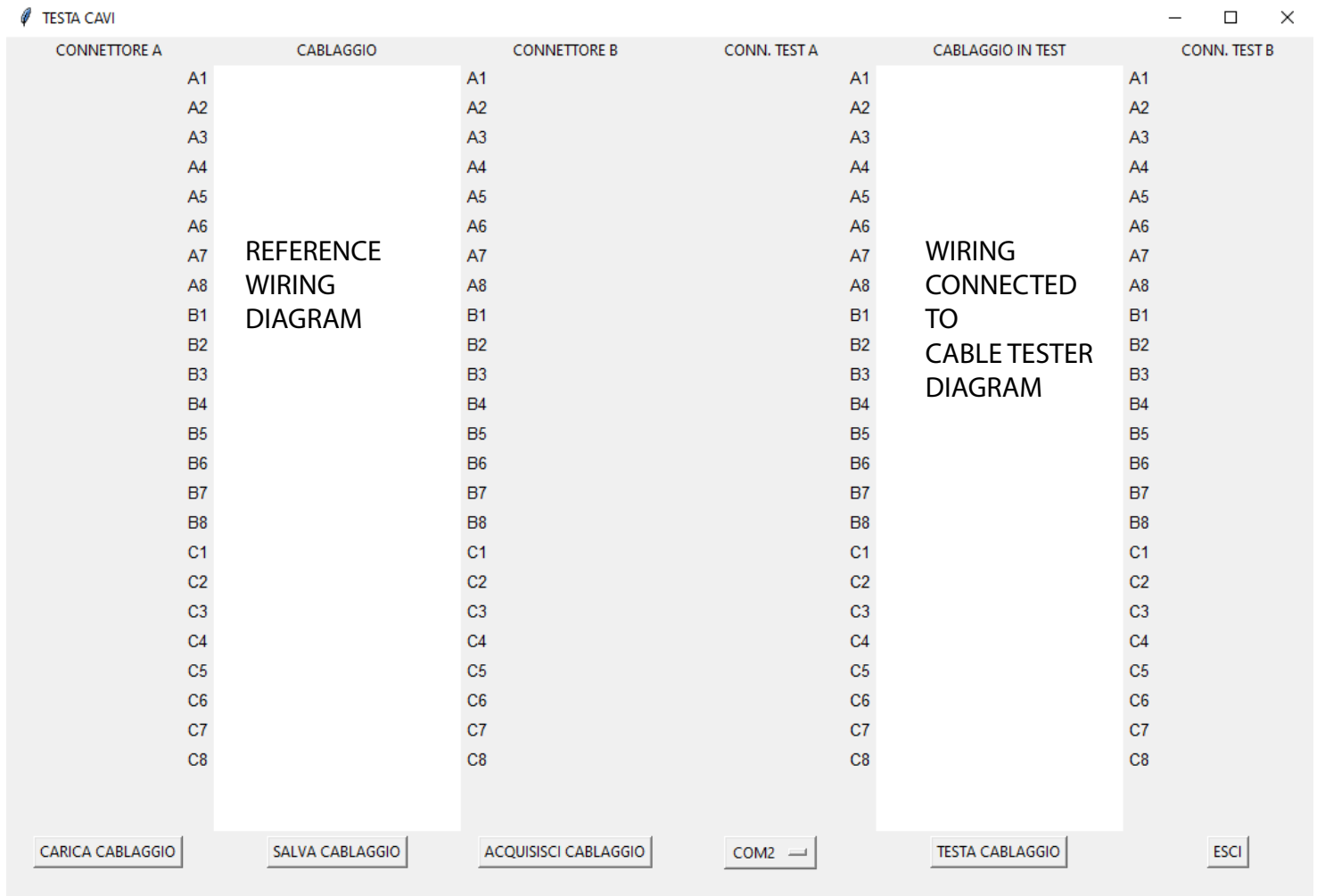

LOAD WIRING : allows you to select the file from which to extract the reference wiring diagram.

SAVE WIRING : allows you to select the file in which to save the reference wiring diagram.

ACQUIRE WIRING : copies the wiring diagram connected to the cable tester into the reference wiring diagram

COM : allows you to select the serial port to which the CABLE TESTER machine is connected

(see previous paragraph)

WIRING TEST : acquires the wiring diagram connected to the CABLE TESTER machine

4. ACQUIRING A NEW WIRING HARNESS

Connect the harness to ports A and B on the CABLE TESTER machine.

Start the CABLE TESTER program.

Press the CABLE TEST button.

Press the ACQUIRE CABLE HARNESS button.

Press the SAVE HARNESS button and save the harness with the harness name.

5. TESTING A HARNESS

Connect the harness to ports A and B on the CABLE TESTER machine.

Start the CABLE TESTER program.

Press the LOAD HARNESS button and load the harness with the correct harness name.

Press the HARNESS TEST button.

The window will become:

- yellow if the selected communication port is wrong
- green if the wiring under test coincides with the loaded reference one
- red if the wiring under test does not coincide with the loaded reference one

6. MAKING THE ADAPTER WIRING

The CABLE TERMINAL tests the flow of current from each output of PORT A to each output of PORT B. A special adapter harness must be made to test both the cables that connect the FCI24 connector to the PREX, CAM, TPS and RAIL connectors and the cables that act as a bridge between the various connectors.

An example :

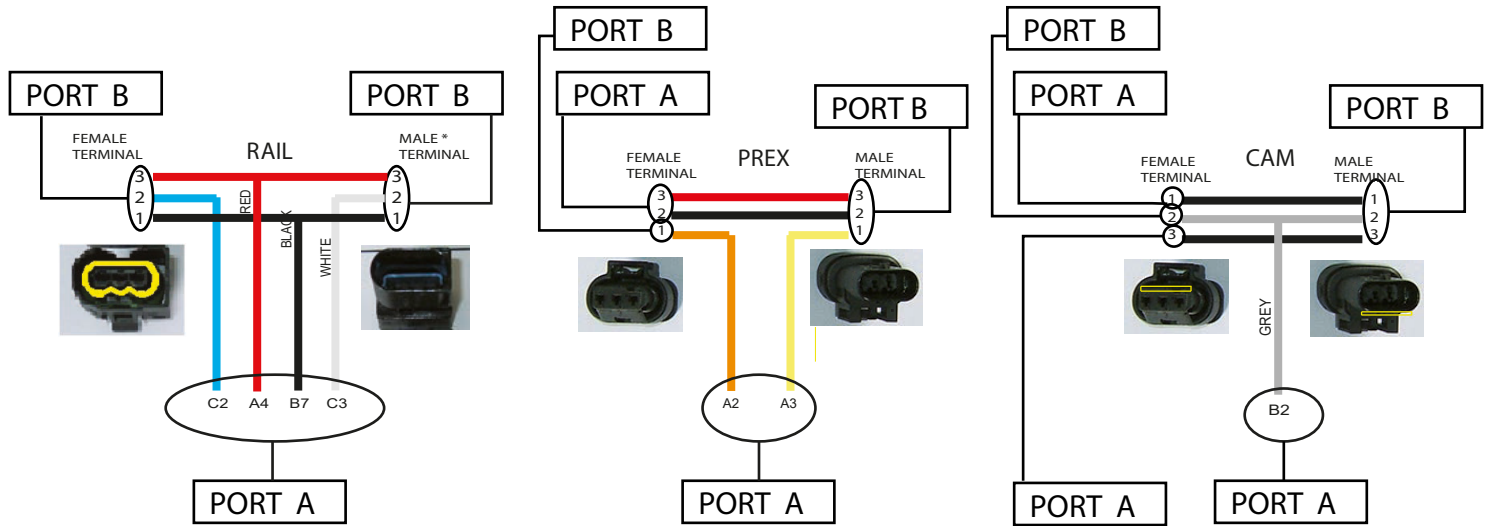

By appropriately connecting the connectors to PORTS A and B, it is possible to test all the wiring connections.

7. EXAMPLE OF ADAPTER WIRING

